

J2C

AVEC FOND

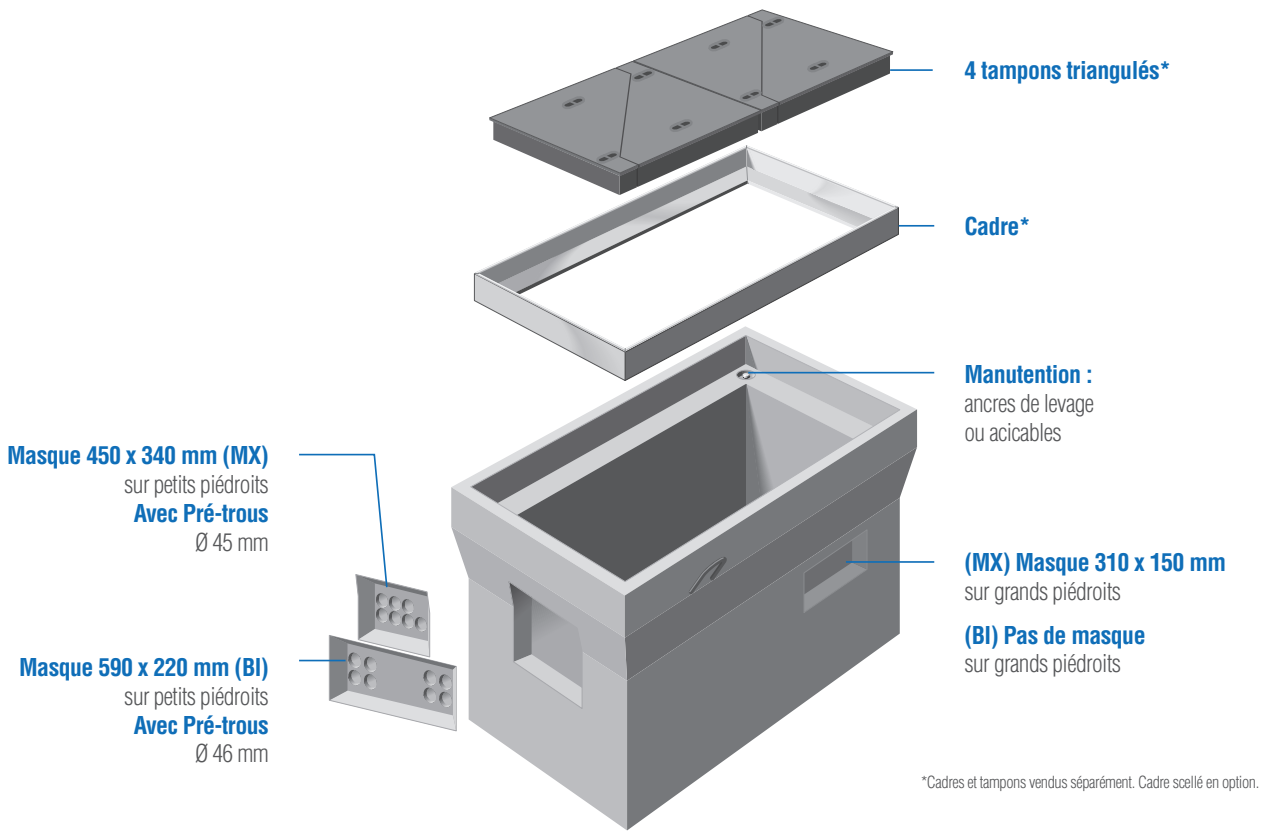

D 400



*Cadres et tampons vendus séparément. Cadre scellé en option.

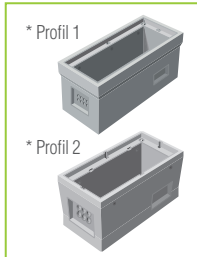
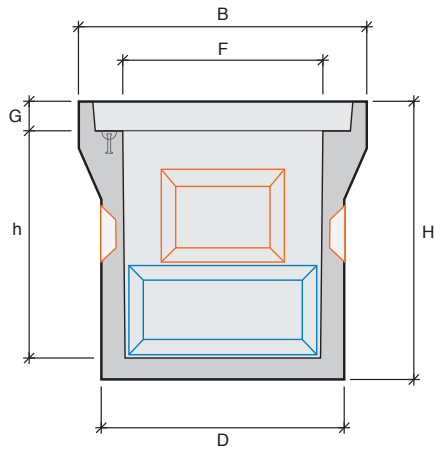
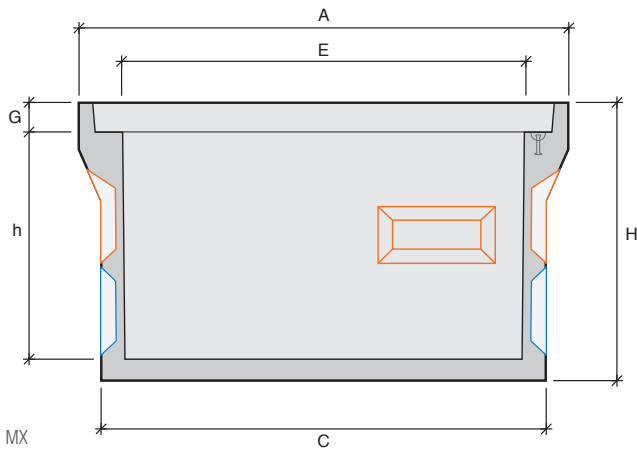

Type L

- L1C
- L1CR
- L2C
- L2CR
- L3C
- L3CR
- L5C

Type J



Type K

- K1C
- K1CR
- K2C
- K2CR
- K3C
- K3CR

Type M

- M1C
- M1CR
- M3C
- M3CR

Type P

- P1C
- P1CR
- P2C
- P2CR

TÉLÉCOMMUNICATIONS
CHAMBRES
SOUS CHAUSSÉE

| Désignation | Code | Usines | Profils* | A Longueur (mm) | B Largeur (mm) | C Longueur radier (mm) | D Largeur radier (mm) | E Longueur intérieure (mm) | F Largeur intérieure (mm) | H Hauteur totale (mm) | h Hauteur utile (mm) | G Hauteur feuillure (mm) | Poids (kg) | Manutention |
|-------------|-----------------|-----------|----------|-----------------------|----------------------|---------------------------------|--------------------------------|-------------------------------------|------------------------------------|--------------------------------|-------------------------------|-----------------------------------|------------|-----------------|
| J2C | J2CSC | BI | 1 | 1820 | 1070 | 1652 | 902 | 1496 | 748 | 1030 | 870 | 80 | 1300 | 2 acicables |
| | 16143910 | MX | 2 | 1830 | 1080 | 1660 | 910 | 1500 | 750 | 1040 | 810 | 140 | 1390 | 2 ancrs de 1,3T |

BI : Arthon / MX : Maxilly